



**02 9452-3566**

**sales@getpacked.com.au**

# Vertical Pallet Strapping Machine

## 3-GPTP-502MV

The 3-GPTP-502MV is a quick and economical solution for low volume vertical strapping. It eliminates the use of manual tools and dispensers, its portability also enables users to easily move it beside the load you want strapped without having to move the pallet. The 3-GPTP-502MV has been redesigned, inheriting all the features from its predecessor, such as the compact strapping head, direct-drive technology with German-made motors and the electronic tension control.



### **Ultimate Simplicity**

Easy operation, simple maintenance



### **Mechanical Outside Tension Control**

Easily set with a dial



### **Affordable**

for every budget

# Vertical Pallet Strapping Machine 3-GPTP-502MV



02 9452-3566

sales@getpacked.com.au

## Standard Features

- Various applications. Suitable for cardboard, concrete blocks and pallets loaded with cardboard boxes.
- Weld-cooling Timer. The weld cooling time can be increased to ensure high joint efficiency under high tension.
- Good for lower height pallets. Designed to strap pallets with a height as low as 380mm.

## Benefits

- Portable.
- Ergonomic, economical.
- Removes the need for manual hand tools/dispensers.

## Technical Data

STRAP WIDTH	9MM-15.5MM
STRAP TENSION	8-70KG
NET WEIGHT	93KG
ELECTRICAL	110V, 220V, 230V, 240V, 50/60HZ, 1PH

## Options

- Battery power supply

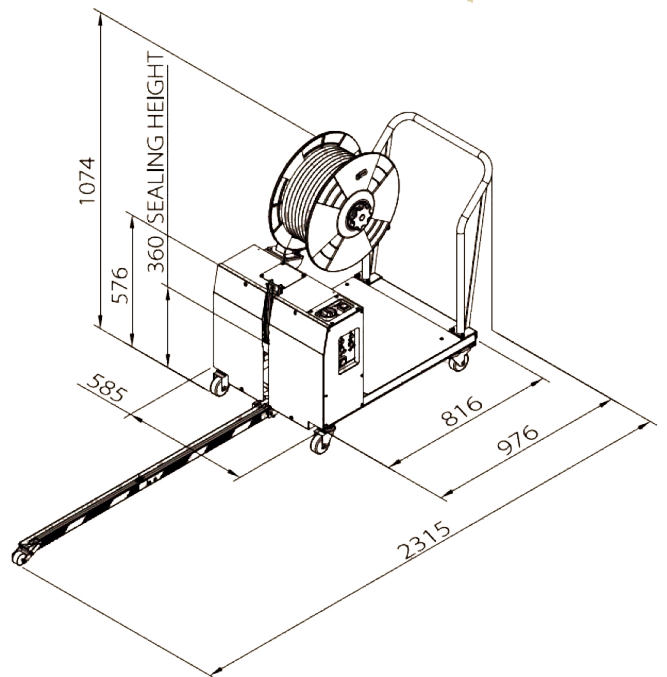

MODEL	3-GTP-502MV	3-GTP-502MVB
Electrical Requirements	110V/220V/230V/240V (50/60Hz) 1PH	110V/220V/230V/240V (50/60Hz) 1PH or Battery
Battery Charging Time		around 5-7 hours (depends on conditions of working environment)
Strap Requirements	PP Strap width 9, 12, 15.5 mm with thickness 0.6~0.8 mm	
Strapping Capacity	45 pallets/hour (2 straps) {Package size: 1200 mm(L) x 800 mm (W) x 1000 mm (H)}	
Tension Range	8 to 70 kg	
Dimension (W) × (D) × (H)	585x2315x1074 mm	585×2315×1074 mm
Minimum Package Height	380 mm (Pallet is included)	
Length of the Sword	1250 mm	
Strap Core Inner Diameter	200 mm / 230mm / 280 mm (Interchangeable)	
Machine Net Weight	93 kg	153 kg
Power Consumption	0.33 kW	
Temperature of working environment	5 ~ 40°C	
Battery spec.		VRLA type, 12V, 50Ah *2 pieces
Battery charge time		5-7 hours (depends on the environment)
Battery capacity		Approx. 1000-1500 strapping cycles per charge (depends on package size and tension)
Battery lifespan		Approx. 300 charges